

TAMS ANNEMARIE

MULTICAT



OVERVIEW

Multipurpose vessel with Anchor handling, Dive support, Cargo, Seabed leveling and Towing capabilities.

PRINCIPAL PARTICULARS

Length overall	21.60m	Operational fuel burn	80-90lt/hr @ 8kn
Width	9.04m	Crane capacity	7.77t@14.4m (Hook only)
Bollard pull	18.6t / 30min	Cargo capacity	65.90t

SURVEY

Registry	AMSA DCV	Call Sign	VNW6381
Class	2B	Crew	5
Official / UVI#	859619	Special pax	10

DIMENSIONS

Length overall	21.60m	Max draft	2.45m, 98% tanks / max cargo
Breadth moulded	9.00m	GRT	135t
Depth moulded	2.04m	Built	2010
Lightship weight	199t	Builder	Neptune marine service BV
Lightship draft	1.92m	Material	Steel

TAMS ANNEMARIE

MULTICAT

VESSEL SPECIFICATION SHEET

PROPULSION

Main engines	2 x Cummins QSK19	Nozzles	Yes
Total Kw	1134	Gearbox	2 x Reintjies WAF 364L 4.48:1
Props	Fixed pitch	Bollard pull	23.20t

PERFORMANCE

Max speed	10 knots @160lt/hr	Port consumption	6lt/hr
Economical speed	8 knots @80-90lt/hr		

DECK EQUIPMENT

Main winch	Hydraulic 50t first layer	Crane	Heila HLRM140-4S
cont....	dual drum, 200m of 32mm wire	Crane accessory	10t SWL running wire
Tugger	10T hydraulic	Clear deck space	65m2 (in crane radius)
Anchoring	Hydraulic windlass, 180kg anchor	Max cargo DWT	65.90t
Aframe	Removable 17t SWL	Deck loading	6.0t/m2
Roller	Bow	Shark jaws	100t SWL

CAPACITIES

Fuel	56.10m3	Lube oil	2.70m3
Fuel transfer	15m3/hr	Waste Oil	1.64m3
Fresh water	28m3	Sullage	STP
FW transfer	15m3/hr	Grey water	1.64m3

ACCOMMODATION

Berths	5	Features	Air conditioned
Cabins	1 single w/ensuite, 2 double	Generators	2 x Caterpillar C4.4

NAVIGATION / COMMUNICATIONS

Radar	Furuno	GPS	Furuno GP150
Sounder	Furuno	Chart plotter	Furuno navnet
HF/Sat Phone	Iridium sat phone	Auto pilot	Seaplot 75
Call Sign	VNW6381	AIS	Furuno FA-150
Compass	Furuno Satellite	MMSI	503486600

OPTIONS

4 point mooring system, crew transfer platform, DMIRS safety case for diving, Dive spread inc Decompression chamber, OVID, RTK Positioning, Running wire for crane (SWL 10t), Box plough or sweepbar.

TAMS ANNEMARIE

MULTICAT



GENERAL ARRANGEMENT

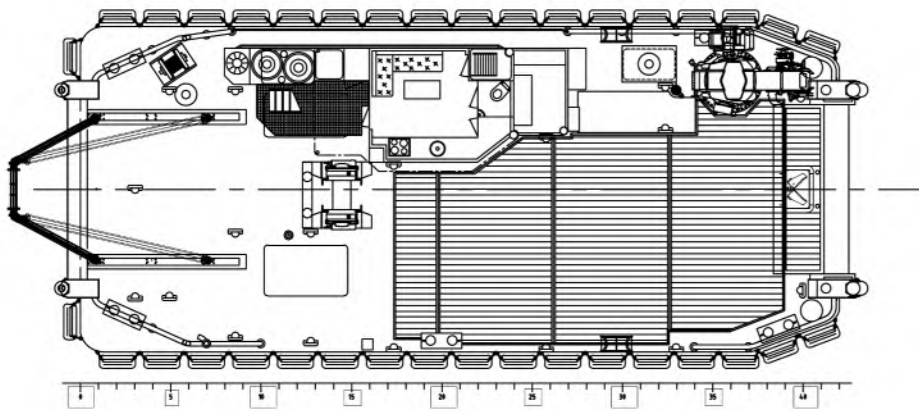
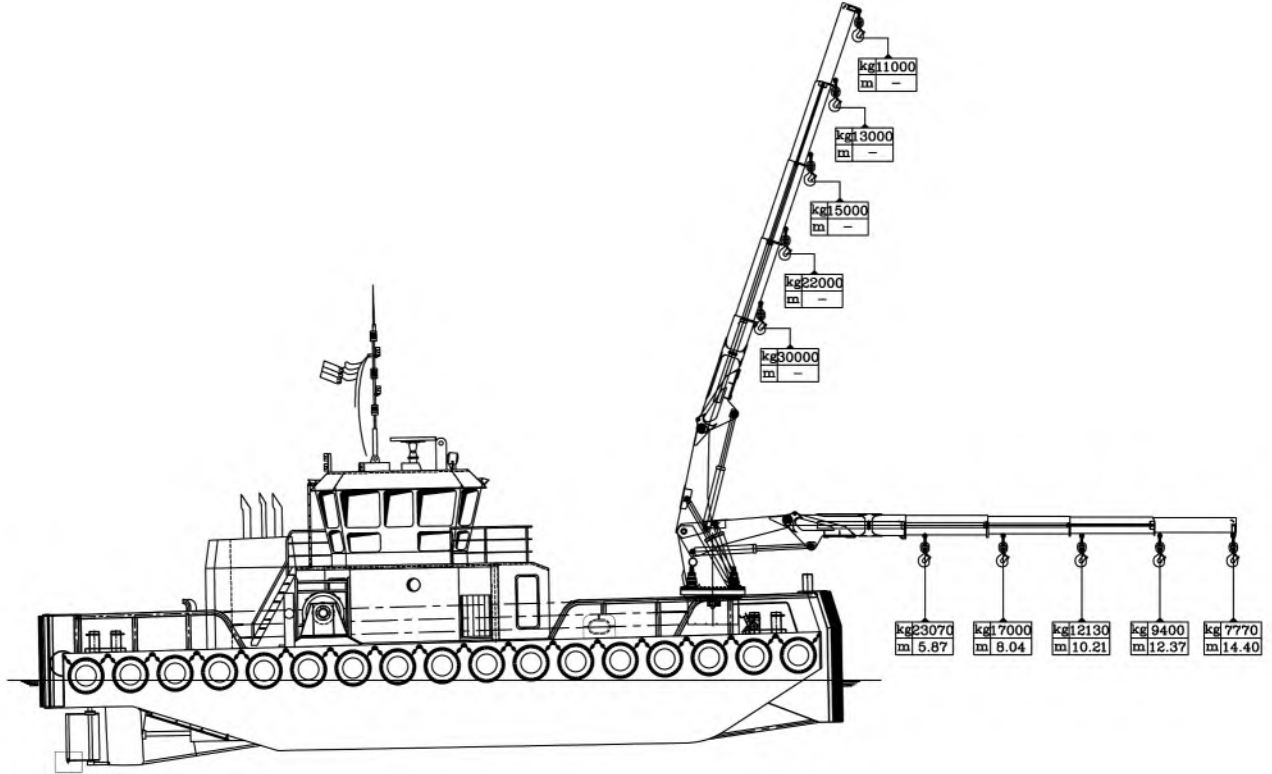

The data on this specification sheet has been published in good faith and should be considered for general information purposes only. It does not warrant its accuracy or completeness and to the full extent allowed by law excludes liability.